

# KENWOOD

**KRC-603C**

**KRC-503**

**KRC-403**

**KRC-S400**

CASSETTE RECEIVER

## **INSTRUCTION MANUAL**

AMPLI-TUNER-LECTEUR DE CASSETTE

## **MODE D'EMPLOI**

RADIO CASETE

## **MANUAL DE INSTRUCCIONES**

KENWOOD CORPORATION

**Take the time to read through this instruction manual.**

**Familiarity with installation and operation procedures will help you obtain the best performance from your new cassette-receiver.**

### **For your records**

Record the serial number, found on the back of the unit, in the spaces designated on the warranty card, and in the space provided below. Refer to the model and serial numbers whenever you call upon your KENWOOD dealer for information or service on the product.

Model KRC-603C/503/403/S400 Serial number \_\_\_\_\_

© B64-0920-00 (KW)

## Contents

### Before use

Safety precautions .....	3
Warning .....	5

### Buttons and Display

Basic operations .....	6
Tuner features .....	6
Cassette player features .....	7
Disc changer control features .....	7
Other features .....	8
Remote .....	8

### Basic operations

Power .....	9
Volume .....	9
Attenuator .....	9
Loudness .....	9

### Basic operations of remote .....

10

### Tuner features

Tuning .....	11
Station Preset Memory .....	11
Auto Memory Entry .....	12
Clean Reception System Circuit (CRSC) .....	12
Direct Access Tuning .....	12

### Cassette player features

Playing Cassette Tapes .....	13
Fast Forwarding and Rewinding Cassette Tapes .....	13
Using Dolby B NR (Noise Reduction) .....	13
Switching Tape Types .....	13
Tuner Call Function .....	13
Blank Skip Function .....	14
Tape Advance Function .....	14
Music Repeat Function .....	14

### Disc changer control features

Playing Discs Using Disc Changer .....	15
Switching Display for Discs .....	15
Fast Forwarding and Reversing Disc Play .....	15

Track Search .....	15
Disc Search .....	15
Direct Track Search .....	16
Direct Disc Search .....	16
Track / Disc Repeat Function .....	16
Track Scan Function .....	17
Disc Scan Function .....	17
Random Play Function .....	17
Magazine Random Play Function .....	17
Presetting Disc Names .....	18

### Other features

Audio Control Setting .....	19
Table of Audio Control Setting .....	19
Selectable Illumination .....	19
Switching Preout .....	20
Clock Display .....	20
Adjusting Time .....	20
Disabled System Indicator (DSI) .....	20
Theft Deterrent Faceplate .....	21

### Installation

Accessories .....	21
Installation Procedure .....	22
Connecting Wires to Terminals .....	23
Installation .....	24

### Troubleshooting guide .....

27

### Specifications .....

30

## Safety precautions

### **▲WARNING**

#### **To prevent injury or fire, take the following precautions:**

- Insert the unit all the way in until it is fully locked in place. Otherwise it may fall out of place when jolted.
- When extending the ignition, battery, or ground wires, make sure to use automotive grade wires or other wires with a 0.75mm or more to prevent wire deterioration and damage to the wire coating.
- To prevent a short circuit, never put or leave any metallic objects (such as coins or metal tools) inside the unit.
- If the unit starts to emit smoke or strange smells, turn off the power immediately and consult your Kenwood dealer.
- Be careful not to drop the unit or subject it to strong shock.  
The unit may break or crack because it contains glass parts.
- Do not touch the liquid crystal fluid if the LCD is damaged or broken due to shock. The liquid crystal fluid may be dangerous to your health or even fatal.  
If the liquid crystal fluid from the LCD contacts your body or clothing, wash it off with soap immediately.

### **FCC WARNING**

This equipment may generate or use radio frequency energy. Changes or modifications to this equipment may cause harmful interference unless the modifications are expressly approved in the instruction manual. The user could lose the authority to operate this equipment if an unauthorized change or modification is made.

### **▲CAUTION**

#### **To prevent damage to the machine, take the following precautions:**

- Make sure to ground the unit to a negative 12V DC power supply
- Do not open the top or bottom covers of the unit
- Do not install the unit in a spot exposed to direct sunlight or excessive heat or humidity. Also avoid places with too much dust or the possibility of water splashing.
- Do not set the removed faceplate or the faceplate case in areas exposed to direct sunlight, excessive heat, or humidity. Also avoid places with too much dust or the possibility of water splashing.
- Do not subject the faceplate to excessive shock, as it is a piece of precision equipment.
- To prevent deterioration, do not touch the terminals of the unit or faceplate with your fingers.
- When replacing a fuse, only use a new one with the prescribed rating. Using a fuse with the wrong rating may cause your unit to malfunction.
- To prevent a short circuit when replacing a fuse, first disconnect the wiring harness.
- Do not use your own screws. Use only the screws provided. If you use the wrong screws, you could damage the unit.

### **IMPORTANT INFORMATION**

You cannot connect the unit directly to the following CD automatic changers. If you want to use older changers with the unit, follow the directions below according to the type of changer you own:

#### **• KDC-C200 / KDC-C300 / KDC-C400**

Use the extension cable and the control box attached to the CD changer, and the optional CA-DS100 converter cord.

#### **• KDC-C301 / KDC-C600 / KDC-C800 / KDC-C601 / KDC-C401**

Use the extension cable attached to the CD changer, and the optional CA-DS100 converter cord.

#### **• C705i / C705si**

Use the extension cable attached to the CD changer, and the optional CA-K300 converter cord.

#### **• KDC-C100 / KDC-C302 / C205 / C705 / non-Kenwood CD changers**

Cannot be used with this model.

### **▲CAUTION**

**You can damage both your unit and the CD changer if you connect them incorrectly.**

## Safety precautions

### NOTE

- If you experience problems during installation, consult your Kenwood dealer.
- If the unit doesn't seem to be working right, try pressing the reset button first. If that does not fix the problem, consult your Kenwood dealer.

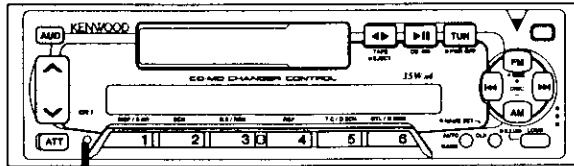

Reset button

### Cleaning the Unit

If the front panel gets dirty, turn off the power and wipe the panel with a dry silicon cloth or soft cloth.

### CAUTION

Do not wipe the panel with a hard cloth or a cloth dampened by volatile solvents such as paint thinner and alcohol. They can scratch the surface of the panel and/or cause the indicator letters to peel off.

### Cleaning the Faceplate Terminals

If the terminals on the unit or faceplate get dirty, wipe them with a dry, soft cloth.

### Cleaning the Tape Head

After you have listened to many cassettes over a long period of time, magnetic powder from the tapes and dust accumulates on the tape head, causing noise and a deterioration in sound quality. Clean the tape head using a cleaning tape or cleaning kit designed for use in car audio systems.

### Handling Cassette Tapes

- Do not play a cassette whose tape has gone slack. In such a case, wind it tight using a pencil or the like in one of the spools. Playing slack cassette tapes can result in the tape tangling around the capstan and/or pinch rollers, causing trouble.
- Do not play a deformed cassette or one whose label is starting to come off, as it can cause the unit to malfunction.
- Do not leave tapes in hot places, such as on dashboards and other spots exposed to direct sunlight, or near heater outlets. They can deform the cassette.
- Avoid using extremely long cassette tapes, such as 100-minute-long tapes. Such tapes are very thin, and can tangle easily around the pinch rollers or other parts inside the unit, causing unit failure.
- Remove a cassette tape from the unit when not listening to it for a while. If you leave a tape in the unit too long, it may stick to the tape head and cause unit malfunction.

## ▲ Warning



### *Dear Customer:*

Selecting fine audio equipment such as the unit you've just purchased is only the start of your musical enjoyment. Now it's time to consider how you can maximize the fun and excitement your equipment offers. This manufacturer and the Electronic Industries Association's Consumer Electronics Group want you to get the most out of your equipment by playing it at a safe level. One that lets the sound come through loud and clear without annoying blaring or distortion — and, most importantly, without affecting your sensitive hearing.

Sound can be deceiving. Over time your hearing "comfort level" adapts to higher volumes of sound. So what sounds "normal" can actually be loud and harmful to your hearing. Guard against this by setting your equipment at a safe level **BEFORE** your hearing adapts.

#### **To establish a safe level:**

- Start your volume control at a low setting.
- Slowly increase the sound until you can hear it comfortably and clearly, and without distortion.

#### **Once you have established a comfortable sound level:**

- Set the dial and leave it there.

Taking a minute to do this now will help to prevent hearing damage or loss in the future. After all, we want you listening for a lifetime.



## We Want You Listening For A Lifetime

Used wisely, your new sound equipment will provide a lifetime of fun and enjoyment. Since hearing damage from loud noise is often undetectable until it is too late, this manufacturer and the Electronic Industries Association's Consumer Electronics Group recommend you avoid prolonged exposure to excessive noise. This list of sound levels is included for your protection.

### **Decible**

#### **Level    Example**

30	Quiet library, soft whispers
40	Living room, refrigerator, bedroom away from traffic
50	Light traffic, normal conversation, quiet office
60	Air conditioner at 20 feet, sewing machine
70	Vacuum cleaner, hair dryer, noisy restaurant
80	Average city traffic, garbage disposals, alarm clock at two feet.

### **THE FOLLOWING NOISES CAN BE DANGEROUS UNDER CONSTANT EXPOSURE**

90	Subway, motorcycle, truck traffic, lawn mower
100	Garbage truck, chain saw, pneumatic drill
120	Rock band concert in front of speakers, thunderclap
140	Gunshot blast, jet plane
180	Rocket launching pad

Information courtesy of the Deafness Research Foundation.



# Buttons and Display

## Basic operations

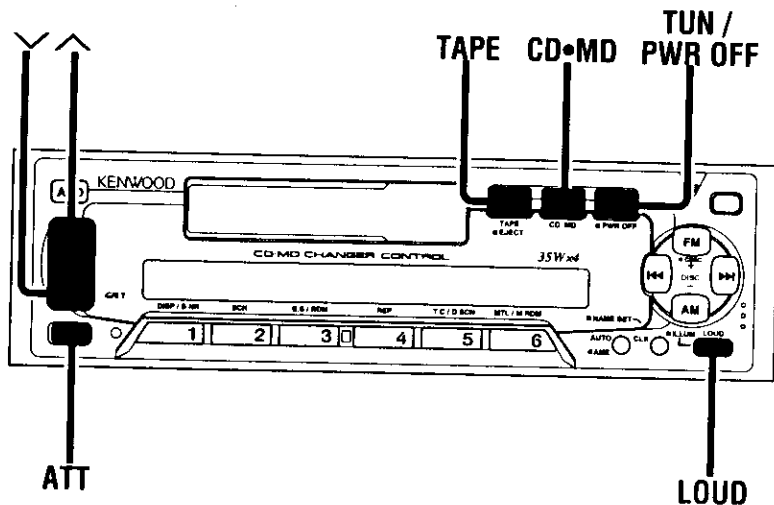

## Tuner features

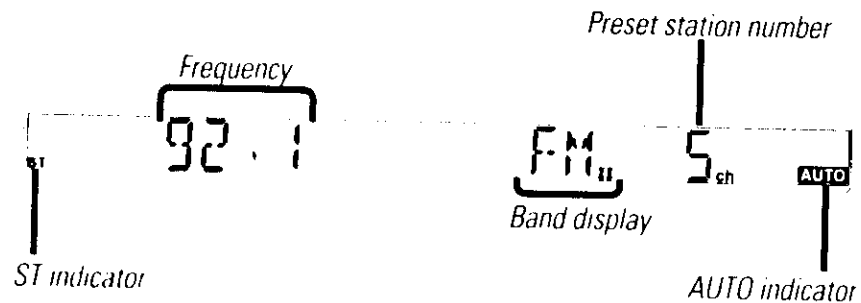
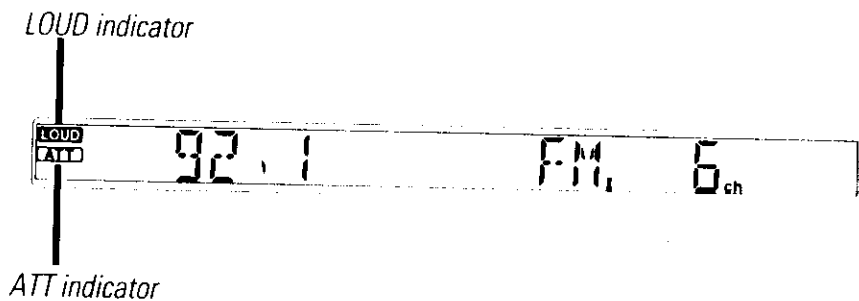
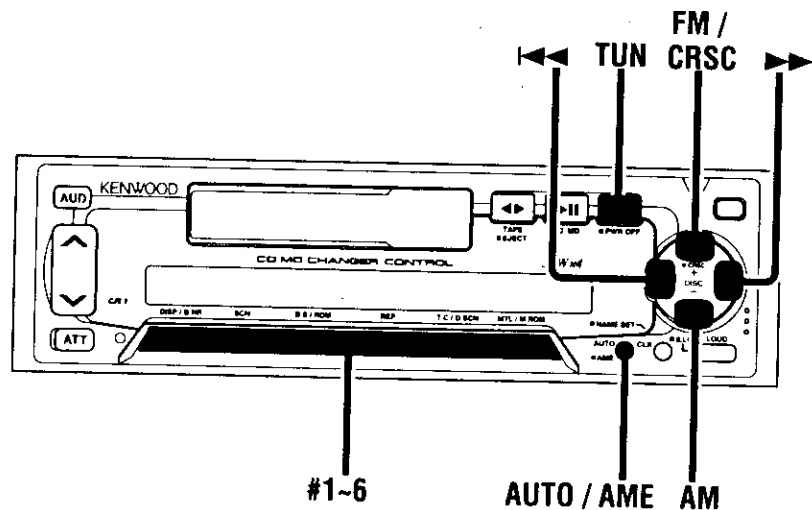

**Cassette player features**

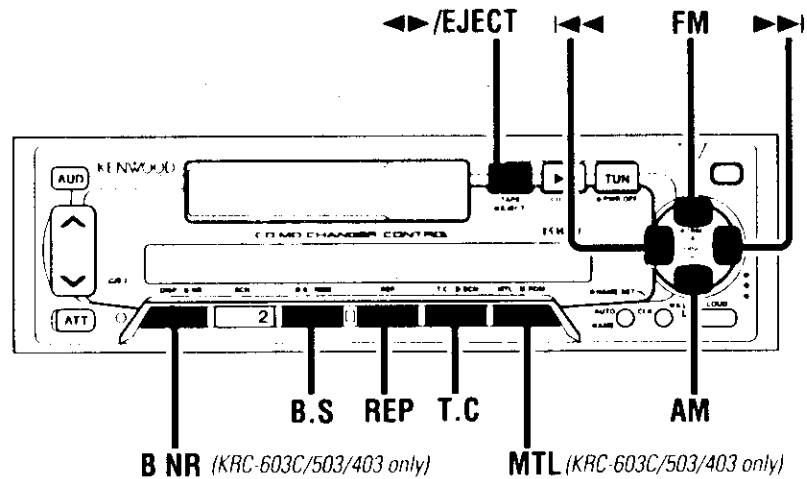

**Disc changer control features**

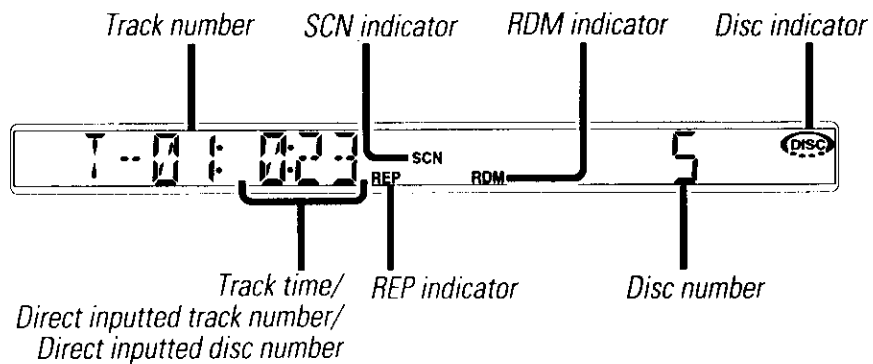
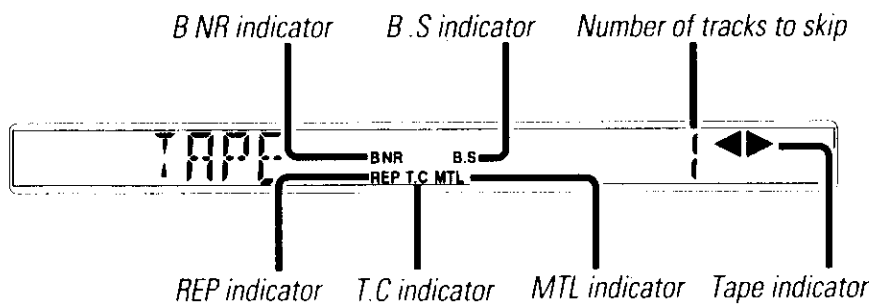
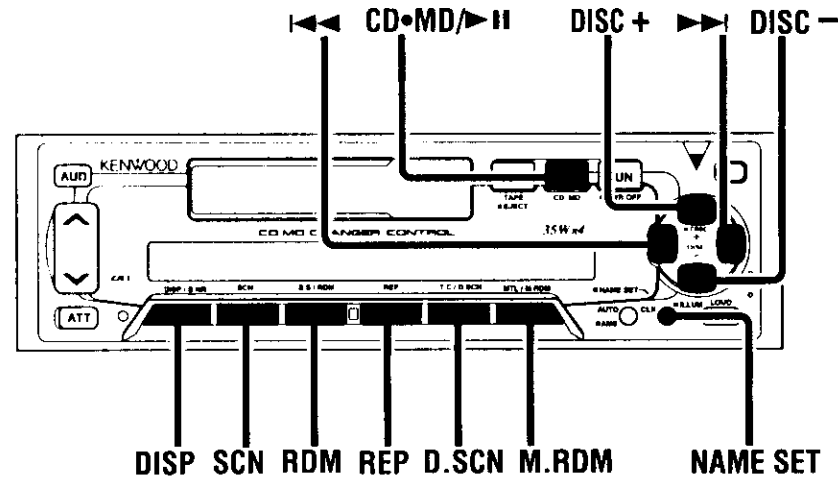

# Buttons and Display

## Other features

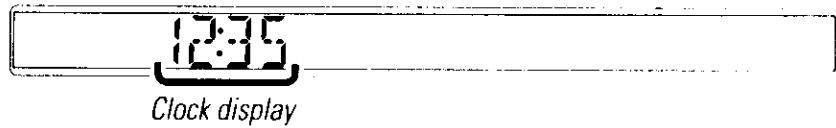
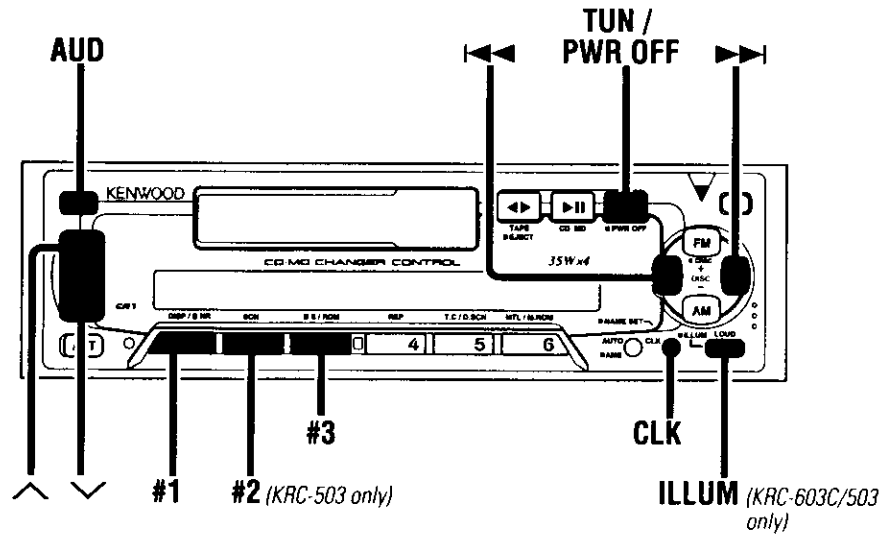

## Remote

Function of the KRC-603C/503, Optional for the KRC-403

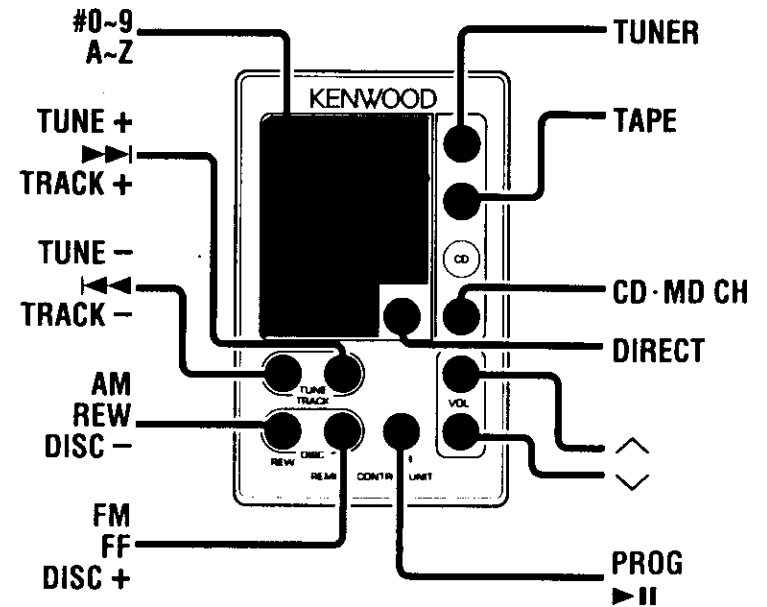



## Basic operations (See page 6)

### Power

#### Turning on the power:

Press one of the following buttons: TAPE, (CD•MD), or TUN

#### NOTE

Turn the power on before completing the following procedures

#### Turning off the power:

Press the PWR OFF button for at least one second

#### Selecting standby mode:

Press the TUN button repeatedly and switch to "ALL OFF."  
When "ALL OFF" is displayed, the standby mode is activated.  
The standby mode turns all functions off while leaving the power to the unit on. Use this mode when you want to have the display illuminated but don't want to listen to anything.

### Volume

#### Increasing Volume:

Press the  $\wedge$  button to turn up the volume.

#### Decreasing Volume:

Press the  $\vee$  button to turn down the volume.

### Attenuator

This function allows you to turn down the volume quickly.

#### Turning Attenuator On/Off:

Press the ATT button to switch the attenuator on and off.  
When the attenuator is on, the ATT indicator blinks.  
When the attenuator is off, the volume returns to the original level.

#### NOTE

Turning the volume all the way down deactivates the attenuator function.

### Loudness

This function amplifies low and high tones when the volume is turned down.  
The LOUD indicator lights up when the loudness function is on.

#### Turning Loudness On/Off:

Press the LOUD button to switch the loudness on and off.

## Basic operations of remote (See page 8)

Function of the KRC-603C/ 503, Optional for the KRC-403

### ▲CAUTION

Do not set the remote on hot places such as above the dashboard.

### Replacing the Lithium Battery:

Use one lithium battery (CR2025).

Remove the case following the instructions as illustrated.

To open

① Keep on slide

② Pull out.

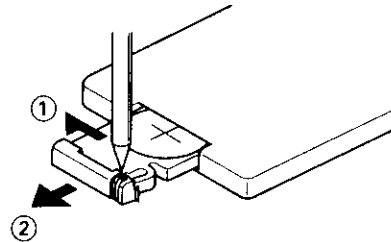

Insert the battery with the + and - poles aligned properly, following the illustration inside the case.

### ▲WARNING

Store unused lithium batteries out of the reach of children. Contact a doctor immediately if the battery is accidentally swallowed.

### All Modes

- **VOL. buttons**  
Press the  $\wedge$  button to turn the volume up.  
Press the  $\vee$  button to turn the volume down.
- **TUNER button**  
Selects the tuner mode. Pressing this button again selects the standby mode.
- **TAPE button**  
Selects the tape mode.
- **CD•MD CH button**  
Selects the disc changer mode.

### Tuner Mode

- **Number buttons**  
Press buttons #1-6 to recall preset stations.  
During direct access tuning, use these buttons to input the frequency of the station.
- **TUNE buttons**  
Press the TUNE - button to decrease the frequency.  
Press the TUNE + button to increase the frequency.
- **AM/FM button**  
Press the AM button to select the AM band.  
Press the FM button to select and switch between FM1, FM2, and FM3 bands.
- **DIRECT button**  
Selects the direct access tuning mode, used to input frequencies directly. Press this button again to cancel the mode while it is operating.

### Tape Mode

- **T.ADV (◀◀/▶▶) buttons**  
Press the ◀◀ button to start play again at the beginning of the current track.  
Press the ▶▶ button to start play at the beginning of the next track.
- **REW button**  
Rewinds the tape.
- **FF button**  
Fast forwards the tape.
- **PROG button**  
Plays the reverse side of the tape. When pressed during fast forward and rewind, this button stops the tape and starts playing it.

## Disc Changer Mode

- **Number/ letter entry buttons**  
Used to specify the track (disc) number used in direct track (disc) searches.  
Use to enter letters during disc name preset
- **TRACK buttons**  
Press the TRACK- button to search through the tracks backward.  
Press the TRACK+ button to search through the tracks forward.  
Use to move the cursor while entering disc name.
- **DISC buttons**  
Press the DISC- button to search through the discs backward.  
Press the DISC+ button to search through the discs forward.  
Select numbers and symbols while entering disc name.
- **▶|| button**  
When a disc is playing, this button pauses the play.  
Press the same button again to start play again.

## Tuner features (See page 6)

### Tuning

**You can choose between auto seek tuning of receivable frequencies and manual tuning.**

- 1 Press the TUN button to turn the radio on.
- 2 Press either the FM or AM button to select the band.  
Each time you press the FM button, the band switches between FM1, FM2, and FM3 (which are used for groups of preset stations).  
Press the AM button to select the AM band.
- 3 Press the AUTO button to switch between auto seek tuning and manual tuning.  
The AUTO indicator lights up only when auto seek tuning is selected.
- 4 • **Auto Seek Tuning**  
Press the ►► button to seek higher frequencies.  
Press the ◀◀ button to seek lower frequencies.  
• **Manual Tuning**  
Press the ►► button to increase the frequency by one step.  
Press the ◀◀ button to decrease the frequency by one step.

#### NOTE

The ST indicator lights up when stereo broadcasts are being received.

### Station Preset Memory

**Store the frequency of a station. You can then recall that station with a single touch of a button.**

- 1 Select the band/station that you want to have stored.
- 2 Press the button (#1-6) that you want to use for the station, for at least two seconds.  
The button number blinks once in the display to indicate that the data has been stored.

#### Recalling a Preset Station:

Press the preset station button (#1-6) for the desired station.  
The number of the recalled station is displayed.

#### NOTE

You can store six stations in each of the FM1, FM2, FM3, and AM bands.

## Tuner features (See page 6)

### Auto Memory Entry

You can automatically store all the receivable frequencies in the band currently being listened to, and then recall them with the touch of a button later. This function is especially useful when you are travelling and do not know what stations are available. Up to six frequencies can be stored this way.

- 1 Select the band for which you want to store stations.
- 2 Press the AME button for at least two seconds to start auto memory entry.  
The numbers of the preset station buttons are shown in order. When all the stations in a certain band are stored in the preset memory, the auto memory entry stops. The tuner then plays the last station received.

#### Recalling a Preset Station:

Press the preset station button (#1-6) for the desired station. The number of the recalled station is displayed.

### Clean Reception System Circuit (CRSC)

Temporarily have reception switched from stereo to mono to reduce multi-path noise when listening to the FM station. The factory default for this function is ON.

#### Turning CRSC On/Off:

Press the CRSC button for at least one second to turn the function on/off. "CRSC ON" is displayed when CRSC is on.

#### NOTE

Strong electrical fields (such as from power lines) may cause unstable sound quality when CRSC is turned on. In such a situation, turn it off.

### Function of remote (See page 8)

### Direct Access Tuning

When you already know the frequency of the station that you want to listen to, you can enter it directly for quick access. (Function of remote control)

- 1 Select the band by pressing the FM or AM button.
- 2 Press the DIRECT button.  
In the display, "—" blinks for 10 seconds.  
If you make no input in the 10-second period, direct access tuning is automatically cancelled.
- 3 Enter the frequency of the desired station whilst the display is blinking.  
If you want to listen to an FM station at 92.1 MHz, for example, press 9, 2, and 1.  
If you want to listen to an AM station at 810 kHz, for example, press 8, 1, and 0.

#### NOTE

- You cannot enter frequencies for a band that are impossible for it to receive.

#### Cancelling Direct Access Tuning:

Press the DIRECT button again.

## Cassette player features (See page 7)

### Playing Cassette Tapes

#### Loading and Playing Cassettes:

Load a cassette with the tape exposed on the right.  
The tape starts playing automatically.  
With side A facing up, the ► indicator lights up when side A is playing, and ◀ when side B is playing.  
The ◀► indicator lights up while play is stopped.

#### Playing Cassettes Already Loaded:

Press the ◀► button to start play.

#### Listening to the other side:

Press the ◀► button.  
Tape play switches to the other side.

#### Stopping and Ejecting Cassettes:

Press the EJECT button for at least one second.  
The tape stops playing and the cassette ejects.

#### NOTE

Remove a cassette from the unit when not listening to it for a while. If you leave it in the unit too long, the tape may stick to the tape head and cause unit malfunction.

### Fast Forwarding and Rewinding Cassette Tapes

#### Fast Forwarding Tapes:

Press the FM button.  
The tape indicator blinks in the direction of the tape as it is being fast forwarded.  
With side A facing up, you see:  
-►- (side A fast forwarding) ◀- (side B fast forwarding)

#### Rewinding Tapes:

Press the AM button.  
The tape indicator blinks in the direction of the tape as it is being rewound.  
With side A facing up, you see:  
-◀- (side A rewinding) ►- (side B rewinding)

#### Canceling:

Press the ◀► button.  
Normal tape play will begin.

Function of the KRC-603C/503/403

### Using Dolby B Noise Reduction

Listen to tapes recorded using Dolby B NR.

#### Turning Dolby B Noise Reduction On/Off:

Press the B NR button to switch Dolby B NR on and off.  
The B NR indicator lights up when it is turned on.

*Dolby noise reduction manufactured under license from Dolby Laboratories Licensing Corporation.  
"DOLBY" and the double-D symbol are trademarks of Dolby Laboratories Licensing Corporation.*

Function of the KRC-603C/503/403

### Switching Tape Types

Select type of tape being played.

#### Switching Tape Types:

Press the MTL (Metal) button to switch the metal tape indicator on and off and to select the tape type.  
Turn the MTL indicator off for normal tape (Type I) playback.  
Turn the MTL indicator on for the following tape types:  
CrO<sub>2</sub> (Type II) FeCr (Type III) Metal (Type IV)  
Selecting the wrong tape type may cause sound quality to suffer.

### Tuner Call

Switch automatically to the tuner while you are rewinding or fast forwarding the tape.

#### Turning Tuner Call On/Off:

Press the T.C button to switch tuner call on and off.  
The T.C indicator lights up when tuner call is turned on.

## Cassette player features (See page 7)

### Blank Skip

Automatically fast forward to the beginning of the next track when long blank spaces (10 seconds or more) are detected, continuing tape playback.

#### Turning Blank Skip On/Off:

Press the B.S button to switch blank skip on and off.  
The B.S indicator lights up when blank skip is turned on.

#### NOTE

- If the blank space contains a lot of noise, blank skip may not work right.
- Sections that are recorded at low levels may trigger blank skip if they last for 10 seconds or more.

### Tape Advance

Rewinds to the beginning of the track currently being listened to (or fast forwards to the beginning of the next track), continuing tape playback.

#### Rewinding tape to the beginning of current track:

Press the ◀◀ button, and the tape will rewind to the beginning of the current track and automatically start playing again.

#### To advance to the beginning of the next track:

Press the ▶▶ button, and the tape will advance to the beginning of the next track and automatically start playing again.

#### NOTE

Tape advance "knows" where a track begins by detecting the blank space preceding it (the space between tracks). However, when the blank space lasts for less than four seconds or contains noise, this function may not operate correctly. Furthermore, sections that are recorded at low levels may trigger the function if they last for four seconds or more.

### Music Repeat

Repeatedly plays the track currently being listened to.

#### Turning Music Repeat On/Off:

Press the REP button to switch music repeat on/off.  
The REP indicator lights up when music repeat is turned on.

#### Canceling Music Repeat:

Press either the REP or ◀▶ button.

#### NOTE

Music repeat "knows" where a track begins by detecting the blank space preceding it (the space between tracks). However, when the blank space lasts for less than four seconds or contains noise, this function may not operate correctly. Furthermore, sections that are recorded at low levels may trigger the function if they last for four seconds or more.

## Disc changer control features (See page 7)

### Playing Discs Using a Disc Changer

#### Playing Discs:

Press the CD•MD button

The disc indicator lights up during disc changer mode

When one disc has finished playing its last track, the next disc in the changer will start playing. When the last disc in the changer has finished, the player will return to the first disc and start playing it.

Disc #10 is displayed as "0"

#### Pausing and Restarting Disc Play:

Press the ►|| button to make the disc pause.

Press the same button again to start play again.

### Switching Display for Discs

Switch the display that appears while discs are playing.

#### Switching Display for Discs:

Each time you press DISP button, the display during disc play switches as follows:

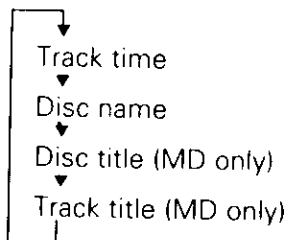

#### NOTE

- You can give names to discs through the presetting disc name function (see p. 18).
- If you try to display the name of a disc that doesn't have one, "NO NAME" is displayed instead.

### Fast Forwarding and Reversing Disc Play

#### Fast Forwarding Disc Play:

Hold down on the ►► button.

Release your finger to play the disc at that point.

#### Reversing Disc Play:

Hold down on the ◀◀ button.

Release your finger to play the disc at the point.

#### NOTE

You cannot use reverse play between tracks when listening to an MD on the MD changer. Instead, the reverse play function is canceled when it reaches the beginning of a track, at which point normal play will automatically resume.

### Track Search

Search forward or backward through the tracks on the disc until you reach the one that you want to listen to.

#### Making a Reverse Track Search:

Press the ◀◀ button to display the desired track number.

Press once to search back to the beginning of the current track, twice to search back to the beginning of the previous track, and so forth.

Play starts at the beginning of the displayed track number.

#### NOTE

Pressing the ◀◀ button while listening to track 1 will only search back to the beginning of that track. The reverse search is not "recycled" to the last track on the disc.

#### Making a Forward Track Search:

Press the ►► button to display the desired track number.

Press once to fast forward to the next track, twice to fast forward to the track after that, and so forth.

Play starts at the beginning of the displayed track number.

#### NOTE

You cannot make a forward track search when listening to the last track on a disc.

### Disc Search

Search forward or backward through the discs in a disc changer.

#### Making a Reverse Disc Search:

Press the DISC- button to display the desired disc number.

## Disc changer control features (See page 7)

Each time the button is pressed, the displayed disc number decreases by one.

Play starts at the beginning of the displayed disc.

### Making a Forward Disc Search:

Press the DISC+ button to display the desired disc number. Each time the button is pressed, the displayed disc number increases by one.

Play starts at the beginning of the displayed disc.

#### NOTE

"LOAD" is displayed when discs are being exchanged on the disc changer.

*Function of remote (See page 8)*

## Direct Track Search

Using the remote, directly input the track number that you want to listen to.

- Using the number buttons on the remote, input the number of the track that you want to listen to.  
The selected track number will blink in the display for 10 seconds.  
If you make no further input in the 10-second period, the number entry mode will automatically be canceled.
- Press either the TRACK+ or TRACK- button while the track number is blinking.  
The track starts playing.

### Canceling Direct Track Search While It Is Operating:

Press the ►|| button.

#### NOTE

You cannot use the direct track search function while doing track or disc scans or using random or magazine-random play.

*Function of remote (See page 8)*

## Direct Disc Search

Using the remote, directly input the disc number that you want to listen to.

- Using the number buttons on the remote, input the number of the disc that you want to listen to.  
The selected disc number will blink in the display for 10 seconds.  
If you make no further input in the 10-second period, the number entry mode will automatically be canceled.

#### NOTE

- Input "0" to select disc 10.
  - If you input more than two numbers all at once, a search will be made only of the last number input.
- Press either the DISC+ or DISC- button while the number inputted is blinking.  
The disc starts playing.

### Canceling Direct Disc Search While It Is Operating:

Press the ►|| button.

## Track / Disc Repeat

Repeat playing the track or the disc currently being listened to.

### Turning Repeat Play On/Off:

Press the REP button to switch repeat track/disc play on and off as follows

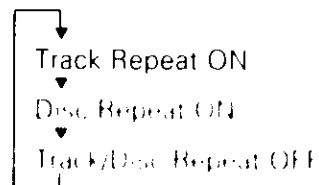

The REP indicator lights up when repeat play is turned on.  
The track number blinks in the display when track repeat is on.  
The disc number blinks in the display when disc repeat is on.

#### NOTE

Repeat play is canceled when you stop playing the disc.



## Track Scan

Successively play the beginning of each track on a disc until you find the track that you want to listen to.

### Turning Track Scan On/Off:

Press the SCN button to switch track scan on and off.  
The SCN indicator lights up when track scan is turned on.  
The first 10 seconds of each track will be played, in order.  
The track number currently being heard blinks in the display.

### Stopping to Listen to the Track Being Scanned:

Press the ►|| or SCN button again to stop the scan and keep on listening to a track normally.

#### NOTE

- Track scan is canceled when you stop playing a disc.
- Track scan only scans each track on a disc once.

## Disc Scan

Successively play the beginning of each disc on a changer until you find the one that you want to listen to.

### Turning Disc Scan On/Off:

Press the D.SCN button to switch disc scan on and off.  
The SCN indicator lights up when disc scan is turned on.  
The first 10 seconds of each disc will be played, in the order they are loaded on the changer.  
The disc number currently being heard blinks in the display.

### Stopping to Listen to the Disc Being Scanned:

Press the ►|| or D.SCN button again to stop the scan and keep on listening to the disc normally.

#### NOTE

- Disc scan is canceled when you stop playing a disc.
- Disc scan only scans each disc on the changer once.
- "LOAD" is displayed when discs are being exchanged on the disc changer.

## Random Play

Play all the tracks on the current disc in random order.

- 1 Press the RDM button to switch random play on and off.  
The RDM indicator lights up when random play is turned on.  
The track number will change over and over in the display as the next track is being selected.  
When the track has been selected, play will begin.  
The selected track number blinks in the display as it is being played.

#### NOTE

When all the tracks on a certain disc have been played using random play, the next disc on the changer will start playing using the same function.

- 2 To change the track being heard, press the ►► button.  
Another track will be selected and played.

#### NOTE

Random play is canceled when you stop playing a disc.

## Magazine Random Play

Play the tracks on all the discs in the disc changer in random order.

- 1 Press the M.RDM button to switch magazine random play on and off.  
The RDM indicator lights up when magazine random play is turned on.  
The disc and track numbers will change over and over in the display as the next track is being selected.  
When the disc/track has been selected, play will begin.  
The selected disc/ track number blinks in the display as it is being played.

#### NOTE

This function is not available with the following models:  
KDC-C200/C300/C400/C301/C401

- 2 To change the track being heard, press the ►► button.  
Another disc/track will be selected and played.

## Disc changer control features (See page 7)

### NOTE

- Magazine random play is canceled when you stop playing a disc.
- The time needed for random selection depends on the number of discs loaded in the disc magazine.

## Presetting Disc Names

### Store the names of discs to be displayed when played.

- 1 Play the disc whose name you want to preset.

### NOTE

- This function is not available for disc changers that do not feature the Disc Name Preset function.
  - This procedure is not to be used to store the disc and track titles for MDs that you record.
- 2 Press the NAME SET button for at least two seconds. "NAME SET" is displayed and the disc name preset mode is entered. The cursor blinks in the position where character input can be made.
  - 3 Press either the ◀◀ or ▶▶ button to move the cursor to the desired position. The ◀◀ button moves the cursor to the left, and the ▶▶ button to the right. You can also move the cursor left or right by pressing the TRACK+ or TRACK- buttons, respectively, on the remote control.
  - 4 Press the DISC+ or DISC- button to display the desired character. Besides the alphabet (capital letters only) and numbers, you can choose the following characters: [, ], /, +, -, \*, =, <, and >.

### NOTE Direct Input (Function of remote)

For units with KDC-C810, KDC-C710, KDC-C660 or KDC-C660C attached, you can directly input letters using the number/letter entry buttons on the remote.

Example: Use the following table to enter the name "DANCE".

Character	Button to press	# Times pressed
"D"	#3	1
"A"	#2	1
"N"	#6	2
"C"	#2	3
"E"	#3	2

- 5 Continue steps 3 and 4 until all the characters are chosen for the name.

### NOTE

You can enter up to eight characters for each name.

- 6 Press the NAME SET button again to finish name entry and leave name preset mode. The disc name is stored and the disc name preset mode is canceled. If you make no entry in a 10-second period, the name will be stored with the characters input so far.

### NOTE

- With the CD changer, you can only store names for up to 100 CDs (The KDC-C710, KDC-C660 and KDC-C660C disc changers can store names for up to 50 discs.), and with the MD changer, you can only store names for up to 30 MDs. If you store the name for a 101st (51st) CD or 31st MD, the first name stored for the type of disc will be erased automatically.
- Discs are identified by their total length and number of tracks. If another disc happens to have the same specifications as one that you have already stored a name for, the name will be displayed for it, too.
- If you want to change the name of a disc, repeat steps 1 and 2 to display the name, and then repeat steps 3 and 4 to input the changes.
- Pressing the reset button does not erase the disc names stored in a disc changer.

## Other features (See page 8)

### Audio Control Setting

#### Adjust various parameters of sound quality.

- 1 Press the AUD button to enter the control mode  
Each time the AUD button is pressed, the adjustment mode display changes as follows:

▶ Bass ▶ Treble ▶ Balance ▶ Fader —————  
Volume ◀ N-F Level (only when being switched KRC 503 only) ◀  
If you do not move to step 2 in five seconds, the unit will switch back to the volume adjustment mode (that is the normal mode).

#### **NOTE** Source tone memory

Each source (tape, FM, AM and disc changer) has its own memory in which to store the bass and treble tone settings.

The settings made for a particular source are recalled automatically whenever you use that source (for example, FM mode uses the tone settings made for FM, AM for AM, etc.).

- 2 Press the √/∧ buttons to adjust the mode shown in the display.  
Use the following table as a guide for adjusting the settings in each mode.

### Table of Audio Control Setting

Adjustment mode (Display)	Operation of Audio control button	
	√ button	∧ button
Bass ("BAS")	Bass decreased.	Bass increased.
Treble ("TRE")	Treble decreased.	Treble increased.
Balance ("BAL")	Left channel emphasized.	Right channel emphasized.
Fader ("FAD")	Rear channel increased.	Front channel increased.
Non-Fading Preout Level ("NF") (KRC-503 only)	Front and rear channels (including pre-out) emphasized.	Non-fading sound emphasized.

#### **NOTE**

The balance of the non-fading sound cannot be adjusted.

#### Function of the KRC-603C/503

### Selectable Illumination

You can switch the color of the button illumination between green and amber.

#### **Switching the illumination:**

Press the ILLUM button for at least one second to switch between amber and green.

**Other features** (See page 8)*Function of the KRC-503***Switching Preout**

**Switch the front preout to non-fading. When you switch to non-fading, you can adjust the volume separately.**

**Switching front preout:**

- 1 Press the TUN button repeatedly and switch the display to "ALL OFF" to enter the standby mode.
- 2 Press the #2 button for at least three seconds to switch front preout to non-fading.  
"NON-FADE" is displayed when non-fading is selected.  
When non-fading is selected, the high-pass filter is automatically applied to the output of the front and rear channels (including preout).

**NOTE**

- When the front preout is switched to "non-fading", the level difference between this preout and the rear preout and front and rear channels can be adjusted. The "non-fading" preout level remains the same while the rear preout and front and rear channel levels decrease by the value set for the "non-fading" feature (see p. 18).
- When the front preout is switched back again, the volume level and fader control settings are returned to the factory set values.

**Clock Display**

**Display the time.**

**Switching to Time Display:**

Keep pressing the CLK button until the clock is displayed

**Adjusting Time**

**Adjust the time.**

- 1 When the time is not displayed, first press the CLK button to display the time.
- 2 While holding down the CLK button, press the ◀◀ or ▶▶ buttons to adjust the time.  
The ◀◀ button adjusts the hour and the ▶▶ button adjusts the minutes.

**NOTE**

Do not press the CLK button for two seconds or more, as it will change to the name preset mode.  
Press the ◀◀ or ▶▶ button quickly to adjust the clock.

**DSI (Disabled System Indicator)**

**A red indicator blinks on the unit after the faceplate is removed, warning potential thieves. The factory default for this function is "ON".**

**Turning Disabled System Indicator On/Off:**

- 1 Turn the power of the unit off
- 2 Whilst pressing buttons #1 and #3 at the same time, press the TUN button.

Repeat steps 1 and 2 above to turn the DSI function back on.

### Theft Deterrent Faceplate

The faceplate of the unit can be detached and taken with you, helping to deter theft.

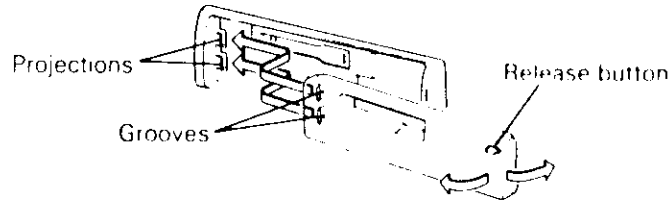

#### Removing the Faceplate:

Press the release button.

The faceplate is unlocked, allowing you to detach it.

#### NOTE

- The faceplate is a precision piece of equipment and can be damaged by shocks or jolts. For that reason, keep the faceplate in its special storage case while detached.

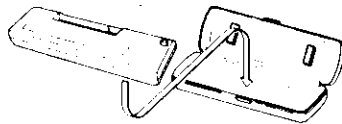

- Do not expose the faceplate or its storage case to direct sunlight or excessive heat or humidity. Also avoid places with too much dust or the possibility of water splashing.

#### Reattaching the Faceplate:

- 1 Align the projections on the unit with the grooves on the faceplate.
- 2 Push the faceplate in until it clicks.  
The faceplate is locked in place, allowing you to use the unit.

### Accessories

	External view	Number of items
(1)		.....1
(2)		.....1
(3)		.....1
(4)		.....2
(5)		.....1
(6)		.....4
(7)		.....4
(8)		.....1

#### CAUTION

The use of any accessories except for those provided might result in damage to the unit. Make sure only to use the accessories shipped with the unit, as shown above.

## Installation Procedure

1. To prevent a short circuit, remove the key from the ignition and disconnect the  $\ominus$  battery.
2. Make the proper input and output wire connections for each unit.
3. Connect the speaker wires of the wiring harness.
4. Connect the wiring harness wires in the following order: ground, battery, ignition.
5. Connect the wiring harness connector to the unit.
6. Install the unit in your car.
7. Reconnect the  $\ominus$  battery.
8. Press the reset button.

### CAUTION

- If your car's ignition does not have an ACC position, connect the ignition wires to a power source that can be turned on and off with the ignition key. If you connect the ignition wire to a power source with a constant voltage supply, as with battery wires, the battery may die.
- If the fuse blows, first make sure the wires aren't touching to cause a short circuit, then replace the old fuse with one with the same rating.
- Do not let unconnected wires or terminals touch metal on the car or anything else conducting electricity. To prevent a short circuit, do not remove the caps on the ends of the unconnected wires or the terminals.
- Connect the speaker wires correctly to the terminals to which they correspond. The unit may be damaged or fail to work if you share the  $\ominus$  wires or ground them to any metal part in the car.
- After the unit is installed, check whether the brake lamps, blinkers, wipers, etc. on the car are working properly.
- Some disc changers need conversion cords for connection. See the section on "Safety Precautions" for details.
- Insulate unconnected wires with vinyl tape or other similar material.

## Connecting Wires to Terminals

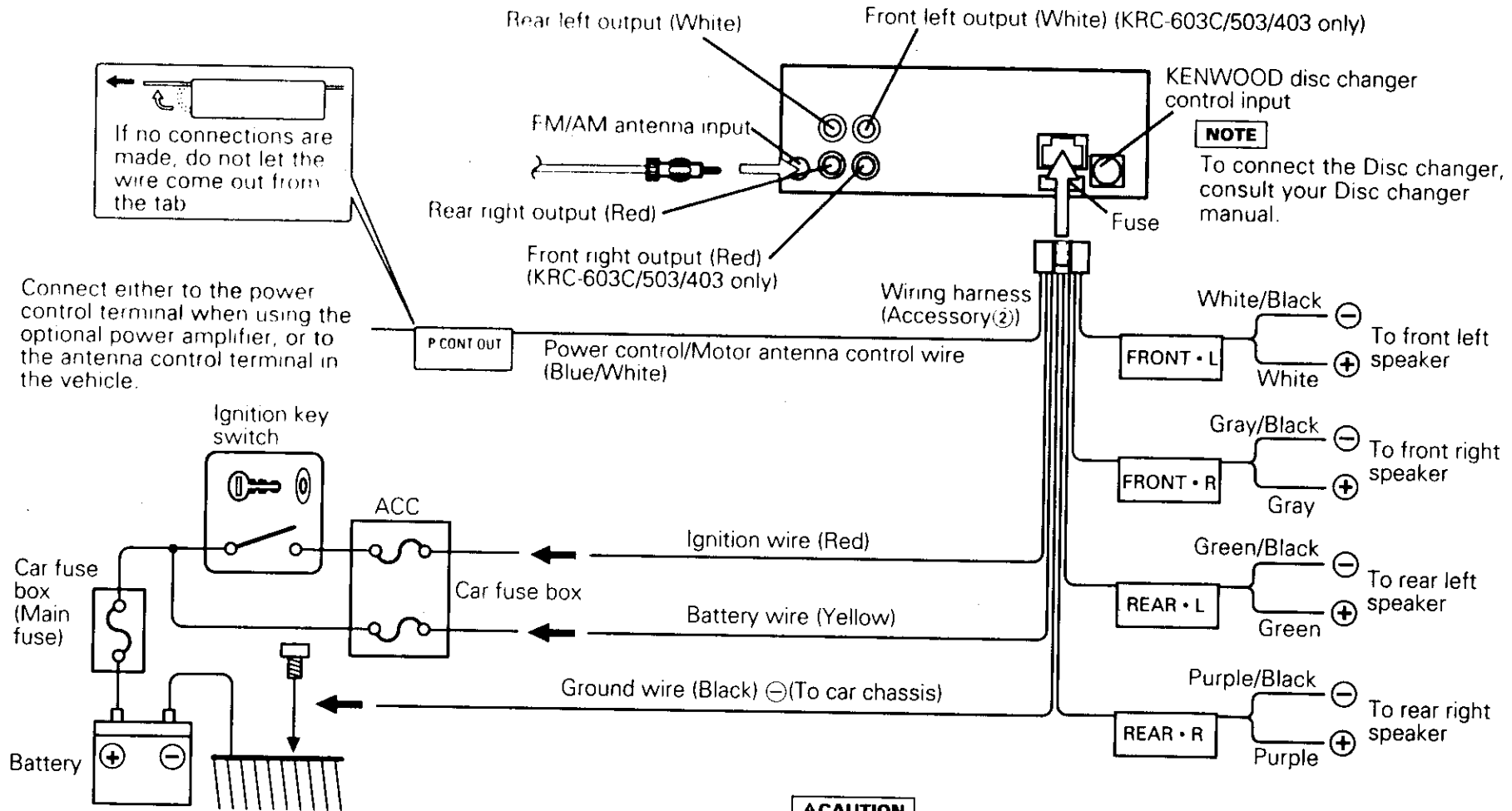

### ⚠ WARNING

If you connect the ignition wire (red) and the battery wire (yellow) to the car chassis (ground), you may cause a short circuit, that in turn may start a fire. Always connect those wires to the power source running through the fuse box.

### ⚠ CAUTION

When only two speakers are being connected to the system, connect the connectors either to both the front output terminals or to both the rear output terminals (do not mix front and rear). For example, if you connect the ⊕ connector of the left speaker to a front output terminal, do not connect the ⊖ connector to a rear output terminal.

## Installation

### ■ Installation

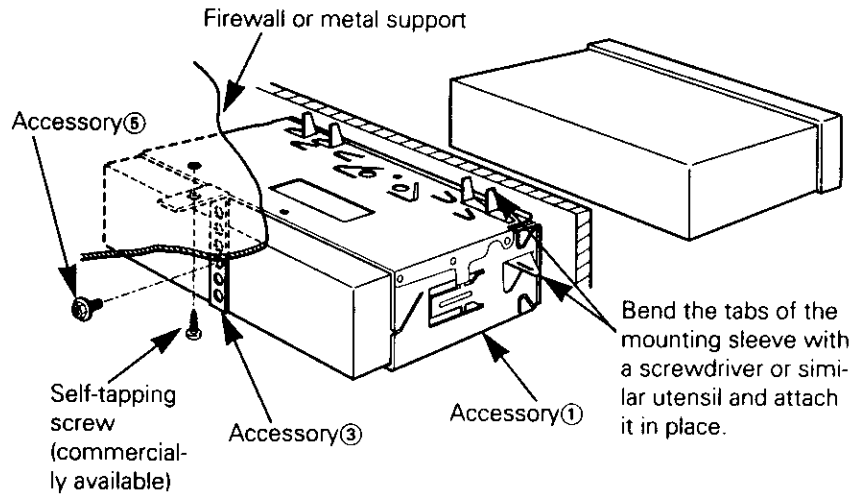

#### NOTE

Make sure that the unit is installed securely in place. If the unit is unstable, it may malfunction (eg, the sound may skip).

### ■ Installing in Japanese-Made Cars

- 1 Refer to the section "Removing the hard rubber frame" and then remove the hard rubber frame.
- 2 Align the holes in the unit (two locations on each side) with the vehicle mounting bracket and secure the unit with the accessory screws.

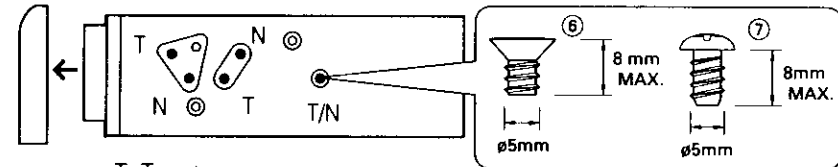

#### CAUTION

- During installation, do not use any screws except for those provided. The use of different screws might result in damage to the main unit.
- Damage may occur if a screwdriver or similar tool is used with excessive force during the installations.



## ■ Removing the hard rubber frame

- 1 Engage the catch pins on the removal tool and remove the two locks on the lower level.  
Lower the frame and pull it forward as shown in the figure.

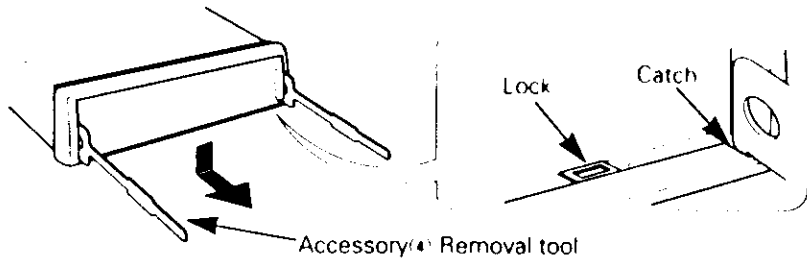

- 2 When the lower level is removed, remove the upper two locations.

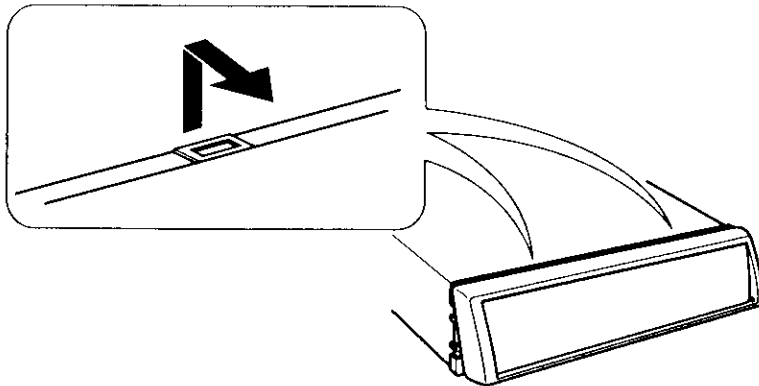

### NOTE

The frame can be removed from the top side in the same manner.

## ■ Removing the Unit

- 1 Refer to the section "Removing the hard rubber frame" and then remove the hard rubber frame.
- 2 Remove the Hex-head screw with integral washer (M4×8) on the back panel.
- 3 Insert the two removal tools deeply into the slots on each side, as shown.

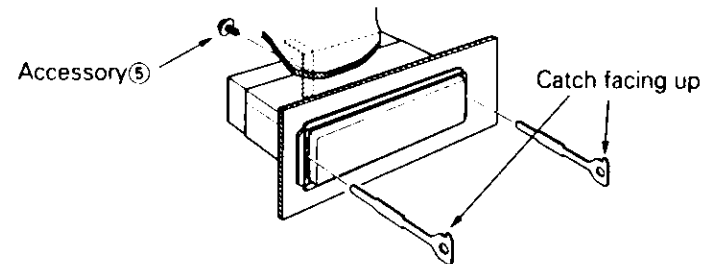

- 4 Lower the removal tool toward the bottom, and pull out the unit halfway whilst pressing towards the inside.

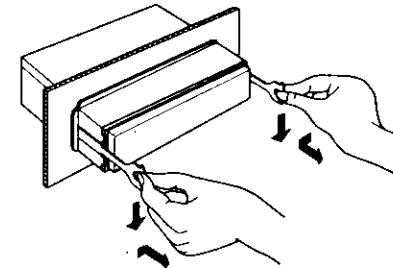

### CAUTION

Be careful to avoid injury from the catch pins on the removal tool.

- 5 Pull the unit all the way out with your hands, being careful not to drop it.

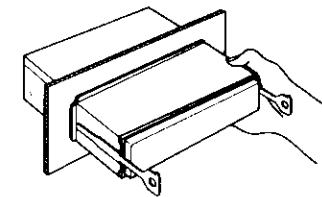

## Installation

### ■ *Screwing the Faceplate on the Unit*

If you want to fasten the faceplate to the main unit so that it does not fall off, screw in the provided screw ( $\varnothing 4 \times 16$  mm) in the hole shown below.

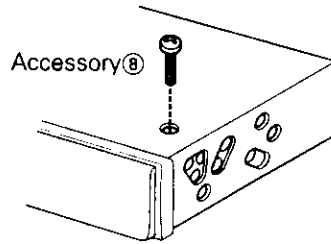

#### **▲ CAUTION**

Never insert the tapite screw ( $\varnothing 4 \times 16$  mm) in any other screw hole than the one specified. If you screw it in another hole, it will contact and may cause damage to the mechanical parts inside the unit.

## Troubleshooting Guide

What might seem to be a malfunction in your unit may just be the result of slight misoperation or miswiring. Before calling service, first check the following table for possible problems.

PROBLEM	POSSIBLE CAUSE	SOLUTION
The power does not turn on	The fuse has blown	After checking for short circuits in the wires, replace the fuse with one with the same rating.
No sound can be heard, or the volume is low	Attenuator is turned on	Turn off Attenuator.
	The fader or balance settings are set all the way to one side	Reset the fader or balance settings.
	The input/output wires or wiring harness are connected incorrectly	Reconnect the input/output wires or the wiring harness correctly. See the section on "Connecting Wires to Terminals".
	The cassette tape is bad.	Try playing another cassette tape. If works fine, the first tape was bad.
Nothing happens when the buttons are pressed.	The computer chip in the unit is not functioning normally.	Press the reset button on the unit (see p. 4).
The sound quality is poor or distorted.	The tape head is dirty.	Clean the tape head, referring to the section on "Cleaning the tape head" (see p. 4).
	One of the speaker wires is being pinched by a screw in the car.	Check the speaker wiring.
	The speakers are not wired correctly.	Reconnect the speaker wires so that each output terminal is connected to a different speaker.
Radio reception is poor.	The car antenna is not extended.	Pull the antenna out all the way.
	The antenna control wire is not connected.	Connect the wire correctly, referring to the section on "Connecting Wires to Terminals".
The memory is erased when the ignition is turned off.	The battery wire has not been connected to the proper terminal.	Connect the wire correctly, referring to the section on "Connecting Wires to Terminals".

## Troubleshooting Guide

### Disc Changer

PROBLEM	POSSIBLE CAUSE	SOLUTION
The disc changer mode cannot be selected.	No cable has been connected to the disc changer input terminal on the unit.	Connect the cable to the disc changer input terminal on the unit.
The specified disc does not play, but another one plays instead.	The specified CD is quite dirty.	Clean the CD.
	The CD is upside-down.	Load the CD with the labeled side up.
	The disc is loaded in a different slot from that specified.	Eject the disc magazine and check the number for the specified disc.
The sound skips.	The disc is severely scratched.	Try another disc instead.
	Something is touching the disc changer.	Remove whatever is touching it.
The display shows that the changer is being played, but no sound can be heard.	The CD is scratched or dirty.	If skipping happens at the same place when the car is stopped, something with the CD is wrong. Clean the CD.
	The computer chip in the unit is not functioning normally.	Press the reset button on the unit (see p. 4).
The specified track will not play.	Random play or magazine random play has been selected.	Turn off random play or magazine random play.

**The following messages are displayed when certain problems are occurring in your system. Take the recommended actions.**

- EJECT** No disc magazine has been loaded in the changer. The disc magazine is not completely loaded.  
⇒ Load the disc magazine properly
- NO DISC** No disc has been loaded in the disc magazine.  
⇒ Load a disc into the disc magazine
- E-04** No disc has been loaded in the disc magazine.  
⇒ Load a disc into the disc magazine.  
The CD is quite dirty. The CD is upside-down. The CD is scratched a lot.  
⇒ Clean the CD and load it correctly.
- BLANK** Nothing has been recorded on the MD.  
⇒ The next MD will automatically be played.
- NO TRACK** No tracks are recorded on the MD, although it has a title.  
⇒ The next MD will automatically be played.
- E-77** The unit is malfunctioning for some reason.  
**E-99** ⇒ Press the reset button on the unit. If the "E- 77", "E- 99" code does not disappear, consult your nearest service center.
- HOLD** The protective circuit in the unit activates when the temperature inside the automatic disc changer exceeds 60°C (140°F), stopping all operation.  
⇒ Cool down the unit by opening the windows or turning on the air conditioner. As the temperature falls below 60°C (140°F), the disc will start playing again.
-  If this indicator continues blinking, it is possible that the tape has become jammed or tangled.  
⇒ Contact the Kenwood dealer if the cassette tape cannot be ejected.

## Specifications

### Specifications subject to change without notice.

#### FM tuner section

Frequency range (200 kHz Space) .....	87.9 MHz – 107.9 MHz
Usable sensitivity (S/N = 30 dB) .....	9.3 dBf (0.8 $\mu$ V/75 $\Omega$ )
Quieting Sensitivity (S/N = 50 dB) .....	15.2 dBf (1.6 $\mu$ V/75 $\Omega$ )
Frequency response ( $\pm$ 3.0 dB) .....	30 Hz – 15 kHz
Signal to Noise ratio (MONO) .....	75 dB
Selectivity ( $\pm$ 400 kHz) .....	$\geq$ 80 dB
Stereo separation (1 kHz) .....	40 dB

#### AM tuner section

Frequency range (10 kHz space) .....	530 kHz – 1700 kHz
Usable sensitivity .....	28 dB $\mu$ (25 $\mu$ V)

#### Cassette player section

Tape speed .....	4.76 cm/sec.
Wow & Flutter (WRMS) .....	0.08 %
Frequency response	
(70 $\mu$ s : KRC-603C/503/403) .....	30 Hz – 20 kHz ( $\pm$ 3 dB)
(120 $\mu$ s : KRC-S400) .....	30 Hz – 14 kHz ( $\pm$ 3 dB)
Separation (1 kHz) .....	43 dB
Signal to Noise ratio	
(Dolby B NR OFF : KRC-603C/503/403) .....	57 dB
(Dolby NR OFF : KRC-S400) .....	54 dB
(Dolby B NR ON : KRC-603C/503/403) .....	65 dB

#### Audio section

Maximum output power .....	35 W $\times$ 4
Full bandwidth power (at less than 1 % THD) .....	20 W $\times$ 4
Tone action	
Bass: .....	100 Hz $\pm$ 10 dB
Treble: .....	10 kHz $\pm$ 10 dB
Preout level / Load .....	1800 mV / 10 k $\Omega$
Preout Impedance .....	$\leq$ 600 $\Omega$

#### General

Operating voltage .....	14.4 V (11 – 16 V allowable)
Current consumption .....	10 A at Rated power
Installation size (W $\times$ H $\times$ D) .....	182 $\times$ 53 $\times$ 154 mm
	7-3/16 $\times$ 2-1/16 $\times$ 6-1/16 in.
Weight .....	1.5 kg
	3.3 LBS